



Metalbilt[®] Steel Roller Shutters

Applications

Factories, warehouses, industrial buildings, car parks, shop fronts or for any opening that must be securely and reliably closed.

Features

- Curtains are constructed from individually roll formed replaceable interlocking slats for additional strength
- Shutters can be supplied with windlocked guides to help retain the curtain in excessive wind conditions and for increased security
- Operation by motorising gearbox drive, manual hand chain or spring balance
- Fixed, sliding and hinged mullions and wicket gate options are available
- An extensive range of powder coating colours (including Colorsteel equivalents) or Zinalume screen options available
- Shutters are custom made to fit the size of opening and structure of building
- Branches in Auckland, Wellington and Christchurch

*Over 60 years of manufacturing experience and continuous refinement.
Service and repairs, 24 hours a day, on all makes of commercial doors.*

Metalbit® Steel Roller Shutter - Specifications

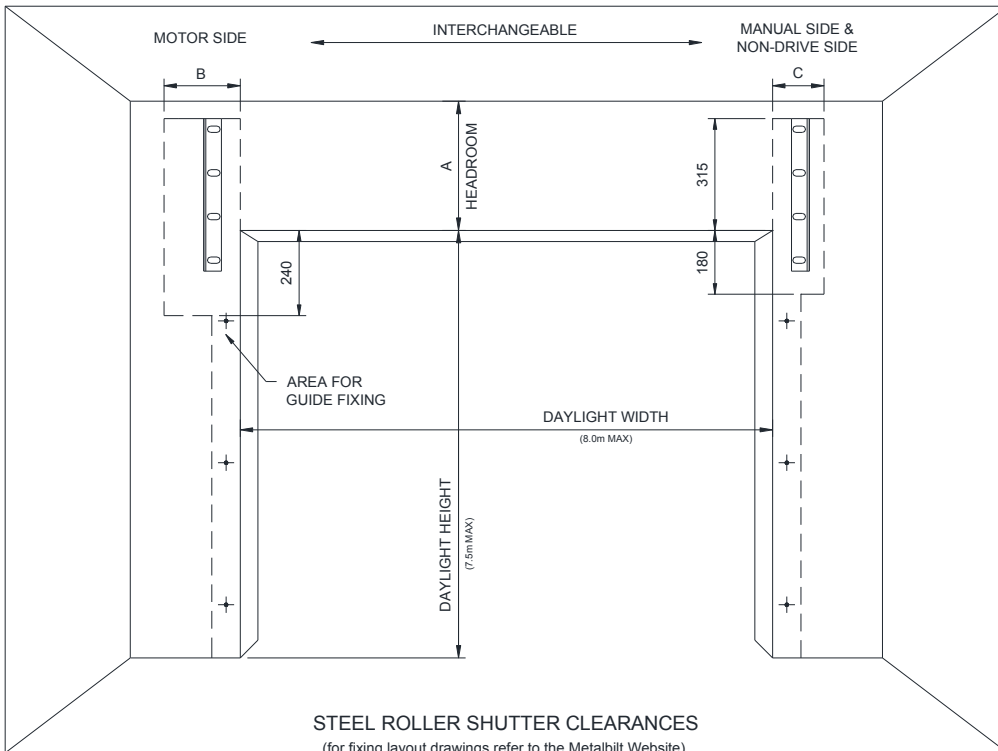

STEEL ROLLER SHUTTER CLEARANCES
(for fixing layout drawings refer to the Metalbit Website)

HEIGHT OF OPENING	HEADROOM ₁	SIDEROOM ₂				INSIDE PROJECTION MOTOR ₃	INSIDE PROJECTION BARREL	INSIDE PROJECTION MANUAL HANDCHAIN
		STANDARD GUIDES		WINDLOCK GUIDES				
		Motor	Non-Drive & Manual	Motor	Non-Drive & Manual			
(m)	A	B	C	B	C	D	E	E
0 - 4.0	450	215	145	260	190	600	360	430
4.0 - 4.5	450	215	145	260	190	600	370	N/A
4.5 - 5.0	465	215	145	260	190	600	385	N/A
5.0 - 6.0	475	215	145	260	190	600	400	N/A
6.0 - 7.5	600	310	180	350	310	630	430	N/A

Note 1: Extra headroom required for mullion doors
 Note 2: Doors over 45m² require greater sideroom
 Note 3: Additional projection may be required with non standard motorising
 For max sizes refer to the Steel Roller Shutter Selection Chart
 (Available on the Metalbit website)

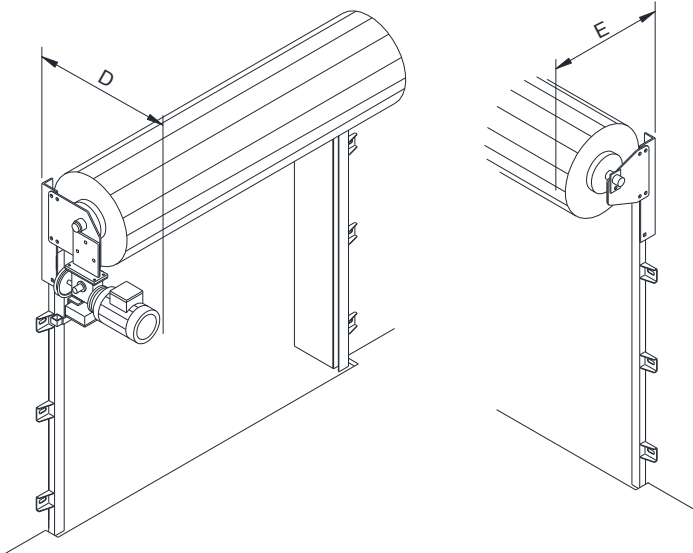

CURTAIN

Assembled from roll formed, galvanised steel interlocked slats, each having an effective width of 100mm. The slats can be replaced individually if damaged. Ventilation slots optional.

BOTTOM BAR

Fitted to the lower edge of the curtain is an extruded aluminium bottom bar with a Neoprene weather seal.

GUIDES

Constructed from roll-formed galvanised steel. Standard guides have a depth of 50mm and fitted with formed bell mouths to accept the shutter curtain. Windlock guides have a depth of 95mm and are recommended for wider openings or where wider windloading/security is required.

BARREL

Shutter barrels are fabricated from galvanised steel tube with a minimum diameter of 165mm and of sufficient wall thickness to ensure that nominal deflection does not exceed safe working conditions. Helically wound counterbalance springs are contained within the barrel for ease of opening and increased safety.

MANUAL OPERATION

Manual operation is by hand chain, driving steel sprockets and 12.7mm pitch roller chain connected to a spring assisted barrel. Manually operated doors can easily be motorised at a later date if required. Spring balanced operation is available on smaller sized shutters.

ELECTRICAL OPERATION

The compact motorising units are powered by a 3 phase 0.37kW electric motor, driving an enclosed worm gearbox with chain reduction to the shutter barrel. Assemblies are supplied complete with reversing starter and limit switches. Standard speed of operation is approximately 185mm per second. Doors over 6m high operate at a reduced rate. Single phase is available. For high cycle or very large doors high rated motors can be supplied. Door controller that accept signals from a range of electronic and electrical equipment are also available. Special motorising options and barrel mounting methods are available on request.

We reserve the right to alter specification without notice and without incurring obligation.

Contact us for details of your nearest Metalbit® representative.

Auckland
Postal Address
 PO Box 71169 Rosebank
 Auckland 1348 New Zealand
Street Address
 26 Timothy Place Avondale
 Auckland 1026 New Zealand
Phone 09 828 1167
Fax 09 828 6358
Email mbilt.auck@metalbit.co.nz

Christchurch
Postal Address
 PO Box 6033 Upper Riccarton
 Christchurch 8442 New Zealand
Street Address
 10 Calgary Place, Hornby
 Christchurch 8042 New Zealand
Phone 03 338 2600
Fax 03 338 4386
Email mbilt.chch@metalbit.co.nz

Wellington
Postal Address
 PO Box 38933 Wellington Mail Centre
 Lower Hutt 5045 New Zealand
Street Address
 33 Marsden Street Melling
 Lower Hutt 5010 New Zealand
Phone 04 568 2933
Fax 04 568 7337
Email mbilt.well@metalbit.co.nz



www.metalbit.co.nz